

# EJ FÖR NYPRODUKTION / NOT FOR NEW PRODUCTION

För nyproduktion gäller K-standard 61780.0002

## 1 ALLMÄNT

Denna standard omfattar gaffelämnets form-, riktnings- och dimensionstoleranser som normalt ska innehållas. I sista avsnittet specificeras mätpunkterna för kontroll av toleranserna.

Basmåtten L, L<sub>1</sub>, H, b, T, T<sub>1</sub> anges vid beställning. Tillverkaren väljer bockningsradie inom följande intervall:

| T mm | R mm    |
|------|---------|
| < 70 | 30 – 40 |
| ≥ 70 | 60 – 70 |

Eventuella avvikelser eller kompletteringar anges vid beställningen.

På grund av olika leverantörer och differentierade krav beroende på användningsområde har gaffelämnena indelats i två typer, där typ 1 finns i två varianter:

- Typ 1a Normal industrihantering
- Typ 1b Normal industrihantering (slitskikt)
- Typ 2 Containerhantering

## 2 TOLERANSER FÖR TYP 1

For new production K-standard 61780.0002 apply

## 1 GENERAL

This standard includes the tolerances regarding form, orientation and dimension that the fork arm forging normally must fulfill. In the last clause measuring points for controlling the tolerances are stated.

The basic dimensions L, L<sub>1</sub>, H, b, T, T<sub>1</sub> are to be given when ordering. The manufacturer chooses bending radius according to this intervals:

| T mm | R mm    |
|------|---------|
| < 70 | 30 – 40 |
| ≥ 70 | 60 – 70 |

Deviations or complements that may occur are to be given when ordering.

Because of different manufacturers and requirements depending on field of application the fork arm forging has been classified into two types, with two variants of type 1:

- Type 1a Normal industrial handling
- Type 1b Normal industrial handling (wearing course)
- Type 2 Container handling

## 2 TOLERANCES FOR TYPE 1

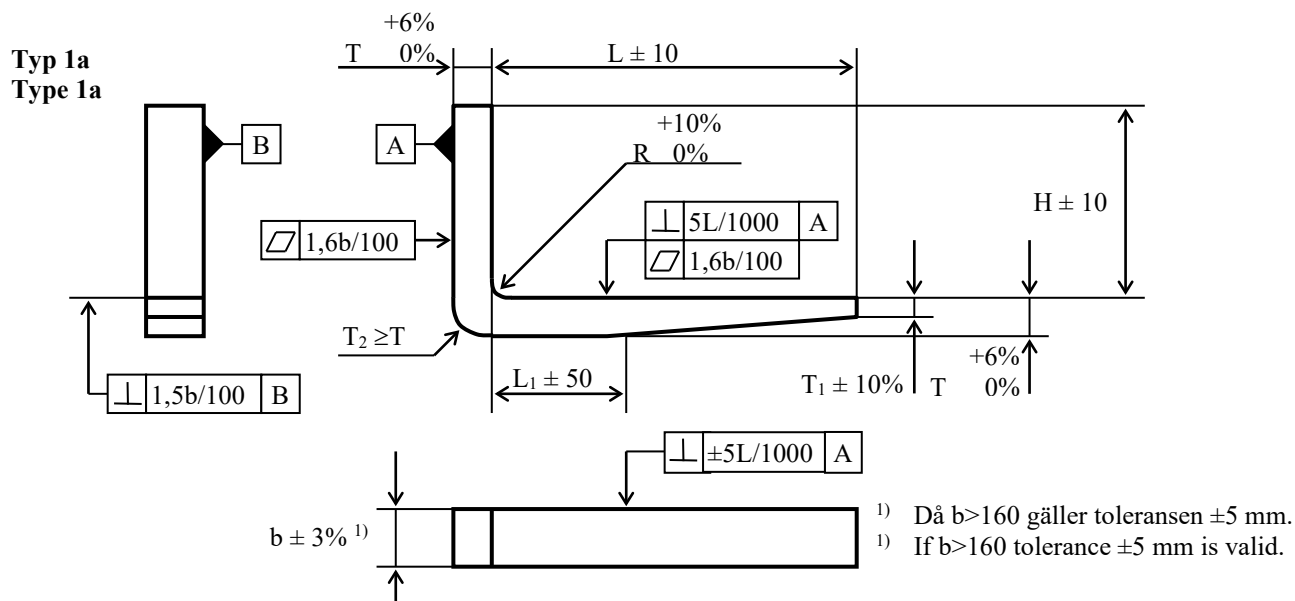

|                                       |                     |                          |              |              |   |
|---------------------------------------|---------------------|--------------------------|--------------|--------------|---|
| <b>K-Standard</b>                     |                     | <b>61780.0001</b>        |              |              | <br>Kalmar is part of Cargotec Corporation |
| Issued by<br>MHR                      | Authorized by<br>SJ | Valid from<br>2009-01-26 | Page<br>2(3) | Edition<br>8 |   |
| <b>Gaffelämne</b><br>Fork arm forging |                     |                          |              |              |   |

## EJ FÖR NYPRODUKTION / NOT FOR NEW PRODUCTION

Typ 1b  
Tvne 1b

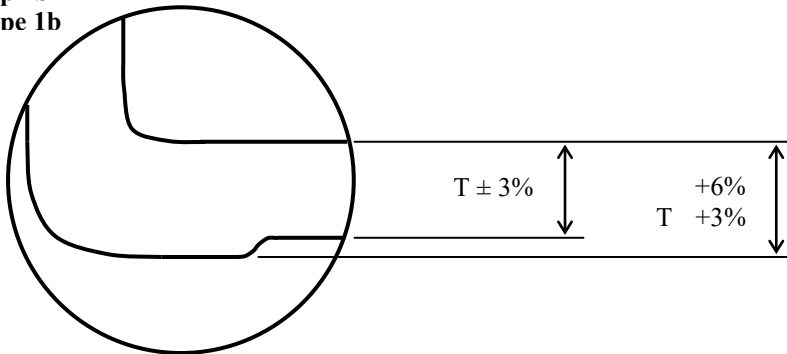

### 3 TOLERANSER FÖR TYP 2

### 3 TOLERANCES FOR TYPE 2

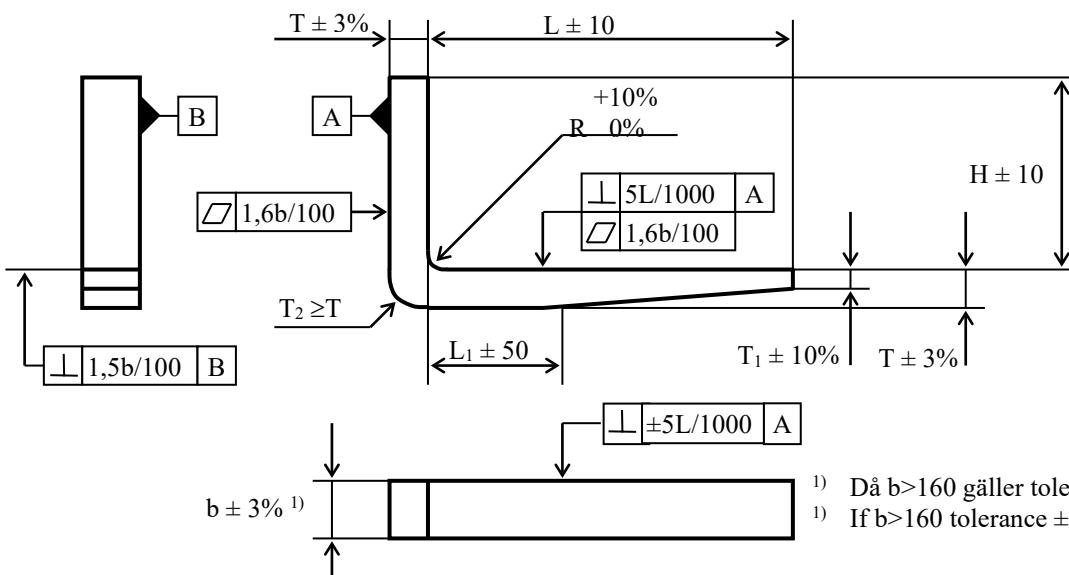

|                                       |                     |                          |              |              |   |
|---------------------------------------|---------------------|--------------------------|--------------|--------------|---|
| <b>K-Standard</b>                     |                     | <b>61780.0001</b>        |              |              | <br>Kalmar is part of Cargotec Corporation |
| Issued by<br>MHR                      | Authorized by<br>SJ | Valid from<br>2009-01-26 | Page<br>3(3) | Edition<br>8 |   |
| <b>Gaffelämne</b><br>Fork arm forging |                     |                          |              |              |   |

**EJ FÖR NYPRODUKTION /  
NOT FOR NEW PRODUCTION**

**4 MÄTPUNKTER**

**4 MEASURING POINTS**

